

cinto[®]



Life Cycle Assessment

Study Completed: October, 2020

Critical Review Completed: November 17, 2020

Critical Review Completed By: WAP Sustainability

LIFE CYCLE ASSESSMENT					
Manufacturer	Humanscale				
Product Name(s)	Cinto®				
Product Type	Guest/Side Chair				
Product Description	Style, comfort and utility come together in the Cinto® chair, a stackable office chair that breaks the number one rule for stacking chairs: it's comfortable. Like Humanscale's ergonomic task chairs, Cinto® was built to support the human body by minimizing pressure points and discomfort.				
LCA Scope, Overall	Cradle to Grave				
LCA Scope, Included Life Cycle Modules	Sourcing and Manufacturing Modules	Delivery and Installation Modules	Use Phase Modules		End of life Modules
	<input checked="" type="checkbox"/> A1	<input checked="" type="checkbox"/> A4	<input checked="" type="checkbox"/> B1	<input checked="" type="checkbox"/> B5	<input checked="" type="checkbox"/> C1
	<input checked="" type="checkbox"/> A2	<input checked="" type="checkbox"/> A5	<input checked="" type="checkbox"/> B2	<input checked="" type="checkbox"/> B6	<input checked="" type="checkbox"/> C2
	<input checked="" type="checkbox"/> A3		<input checked="" type="checkbox"/> B3	<input checked="" type="checkbox"/> B7	<input checked="" type="checkbox"/> C3
	Benefits and Loads beyond System Boundary: <input type="checkbox"/> D				
Functional or Declared Unit	The functional unit is one chair.				
Summary of Impact Categories Measured	<input checked="" type="checkbox"/> Global Warming Potential <input checked="" type="checkbox"/> Acidification Potential <input checked="" type="checkbox"/> Eutrophication Potential <input checked="" type="checkbox"/> Smog Creation		<input checked="" type="checkbox"/> Ozone Depletion Potential <input checked="" type="checkbox"/> Water Consumption <input checked="" type="checkbox"/> Fossil Resource Scarcity		

Reference Standards	<input checked="" type="checkbox"/> ISO 14040	<input type="checkbox"/> ISO 21930	<input type="checkbox"/> Others (Specify Below):
	<input checked="" type="checkbox"/> ISO 14044	<input type="checkbox"/> EN 15804	
Reference PCR (If Applicable)	BIFMA PCR for Seating: UNCPC 3811		
LCA Study Conducted by	Date Completed	October, 2020	
	LCA Practitioner	Stephanie Richardson, Sustainability Coordinator, Humanscale	
Independent LCA Review Details	Date of Final Approval	November 17, 2020	
	LCA Reviewer	Manasa Rao, Sustainability Data Manager and Researcher, WAP Sustainability	
	Type of Review	<input type="checkbox"/> Internal	<input checked="" type="checkbox"/> External
LCA Expiration Date	New expiration: May 16, 2024		
LCA Software and Version	OpenLCA		
LCA Database(s) and Version(s)	Ecoinvent database, version 3.6 APOS unit regionalized		
Applicable Region(s)	Global		
Link to Publicly Available Version of LCA (If Applicable)	https://www.humanscale.com/resources/designer-toolkit/green-design.cfm		



Cinto®

TABLE OF CONTENTS

1	EXECUTIVE SUMMARY.....	7
2	GENERAL INFORMATION.....	7
	2.1 Company Profile	7
	2.2 Reporting Date	7
	2.3 Goal of the study and Intended Application	7
	2.4 Target Group / Audience	8
	2.5 Comparative Assertions and Public Disclosure	9
	2.6 ISO 14040/44 and PCR Compliance	9
3	SCOPE OF THE STUDY.....	9
	3.1 Functional Unit	9
	3.2 Product Description.....	9
	3.2.1 Product Description and Specifications.....	9
	3.2.2 Technical Data	10
	3.3 System Boundary.....	10
	3.4 Material Acquisition and Pre-processing Stage.....	13
	3.5 Production	13
	3.6 Distribution, Storage, and Use	14
	3.7 End-of-life Management	14
	3.8 Cut-off Criteria.....	15
	3.9 Allocation Procedures	15
	3.10 Data Quality Requirements	15
	3.10.1 Geographical Coverage	15
	3.10.2 Time Coverage.....	16
	3.10.3 Technical Coverage.....	16
	3.10.4 Treatment of Missing Data	18
4	LIFE CYCLE INVENTORY ANALYSIS	18
	4.1 Data Collection and Calculation Procedures	18
	4.2 Limitations of the Study	18
5	LIFE CYCLE IMPACT ASSESSMENT.....	19
	5.1 Selection of Impact Parameters	19
	5.2 LCA Results	20

5.2.1 Cinto	20
5.3 Top 5 Processes Contributing to Energy Consumption	23
5.4 Top 5 Processes Contributing to Carbon Footprint	24
5.5 Top 5 Processes Contributing to Water Depletion	25
5.6 Sensitivity Analysis	26
6 INTERPRETATION.....	26
7 WORKS CITED	27
APPENDIX B. Verification Documents	28

TABLE OF TABLES

Table 1: Technical Details.....	10
Table 2: Summary of Included Life Cycle Stages.....	11
Table 3: Material Composition.....	13
Table 4: End of Life Management.....	15
Table 5: Secondary Dataset Reference.....	16
Table 6: Impact Parameters.....	19
Table 7: Cinto Piscataway LCA Results.....	20
Table 8: Cinto Fresno LCA Results.....	21
Table 9: Cinto Dublin LCA Results.....	22
Table 10: Top 5 Processes Contributing to Energy Consumption	23
Table 11: Top 5 Processes Contributing to Carbon Footprint.....	24
Table 12: Top 5 Processes Contributing to Water Consumption	25
Table 13: Sensitivity Analysis Results.....	26

TABLE OF FIGURES

Figure 1: Product Specifications	10
Figure 2: System Boundary Diagram	12

1 EXECUTIVE SUMMARY

This critical review is being done by WAP Sustainability. The objective of the critical review is to ensure that this assessment meets the intent of the relevant imperatives within the Living Product Challenge; Water Footprint 04, Energy Footprint 06, and Net Positive Carbon 14, for greenhouse gas calculations for Scope 3, category 1: Purchased Goods and Services and to increase LEED credit contribution for this product.

The results presented herein will not be used as the sole basis for a comparative assertion.

2 GENERAL INFORMATION

2.1 COMPANY PROFILE

Humanscale was founded in 1983 by CEO Bob King with a focus on high-performance tools that support a healthy, more active way of working. Humanscale is now a global ergonomics and furniture leader with a reputation for designing intuitive products which improve the comfort and health of office workers. Humanscale's global headquarters is located in New York, NY and the company has offices and manufacturing throughout North America, Latin America & The Caribbean, Europe, Asia Pacific, Oceania, The Middle East and Africa.

- The LCA commissioner: Humanscale
- The LCA practitioner(s): Stephanie Richardson, Sustainability Coordinator; an employee of Humanscale.

The LCA modeling, results interpretation and report have been conducted according to the relevant requirements of the International Standards on LCA, including ISO 14040 and ISO 14044.

In addition, the LCA modeling, results interpretation and report have been conducted in conformance with established Product Category Rules (PCR). Specifically, this LCA followed the PCR for seating (BIFMA PCR for Seating - Version 3 UNCPC 3811).

2.2 REPORTING DATE

The LCA study was commenced in October 2020 and a draft was submitted for critical review to WAP Sustainability in November 2020. The final approval of the document took place on November 17, 2020.

2.3 GOAL OF THE STUDY AND INTENDED APPLICATION

The intended application of this LCA is to support Humanscale in applying "life cycle thinking" to discover potential ways to further improve the environmental performance of the Cinto® chair, with a particular focus on one or more of the following impact categories: energy consumption, water consumption, and climate change, including the emissions and the possible sequestration of greenhouse gases.

Additionally, the study was also conducted to support the following certifications, reporting schemes and programs.

1. Living Product Challenge certification:

Some of the certification criteria within Living Product Challenge, which are referred to as “imperatives”, include a requirement related to the characterization of the product’s cradle-to-gate footprint on specific impact categories. The required impact categories include climate change, water consumption and energy consumption. Additionally, the imperatives go on to call on manufacturers to identify the five major determinants, referred to as Hotspots, of a product’s cradle-to-gate environmental footprints. Ultimately companies are required to establish plans to reduce these footprints and to create positive impacts (called “handprints”) which are larger than the remaining footprint. Accomplishing the above requires a company to complete a life cycle assessment (LCA) on the products they are seeking certification for.

2. Greenhouse gas calculations for Scope 3, category 1: Purchased Good and Services:

The LCA model and results will be used to calculate upstream Greenhouse Gas (GHG) impacts related to the production of Humanscale products. This calculation will then be used to disclose Scope 3 emissions related to material extraction in Humanscale’s annual Carbon Disclosure Project (CDP) submittal.

3. ANSI/BIFMA LEVEL e3 certification:

LEVEL certification is based on the ANSI/BIFMA e3 standard and includes several credit points for calculation of product impacts through various phases of the life cycle. This LCA will be used to achieve these credits.

4. USGBC LEEDv4.1 MR credit:

LEEDv4.1 awards point contribution to products that have a third-party verified LCA in accordance to ISO14040. The LCA must be publicly available and include a scope of at least cradle-to-gate. This LCA will be posted publicly and will be used by Humanscale to support their customer’s point contribution to this credit.

5. Calculations toward Net Positive impact:

Humanscale aims to have a net positive impact while manufacturing mass produced goods. Along with reductions in negative impacts from manufacturing, additional positive impacts are created with restorative initiatives. The LCA is used to understand the full amount of negative impacts, and therefore the minimum required amount of positive impacts required to achieve a state of net positive impact.

2.4 TARGET GROUP / AUDIENCE

The intended audience of the study includes:

- Customers, particularly those looking to achieve LEED credits related to product specific LCAs.
- Third-party verification professionals who will confirm compliance to ISO14040/44 and the product category PCR.
- Third-party verification professionals who will review the documentation to assure conformance to certifications and reporting schemes listed in the Goal and Intended Application section above.
- Employees of Humanscale who will use the LCA information to inform product design and company strategy.

2.5 COMPARATIVE ASSERTIONS AND PUBLIC DISCLOSURE

This LCA will be publicly available; however, this study was not completed with the intent that comparative assertions would be made using its results. Additionally, the study is not comparative in nature and only discloses the impacts associated with single products or groups of products and makes no claims of the environmental performance of the products in the study against other products.

2.6 ISO 14040/44 AND PCR COMPLIANCE

This LCA has been critically reviewed for compliance with;

- ISO 14040/44
- BIFMA PCR for Seating: UNCPC 3811, Version 3

The critical review statement and checklist are included in the appendix of this document.

3 SCOPE OF THE STUDY

3.1 FUNCTIONAL UNIT

The primary function of the product is to provide seating to one individual.

The functional unit for this LCA study follows the requirements for defining a function unit according to the BIFMA PCR for Seating: UNCPC 3811 version 3. This PCR states that “the functional unit shall be one unit of seating to seat one individual, maintained for a 10-year period.” Although the warranty for Cinto® is 15 years, and it is expected to perform at least as long as its warranty period, this LCA follows the PCR requirement, and the functional life of the product is assumed to be ten years.

3.2 PRODUCT DESCRIPTION

3.2.1 Product Description and Specifications

Developed in the Humanscale Design Studio by a global team of designers and engineers, Cinto® puts comfort first. As well as offering unrivaled support in a streamlined aesthetic, its lightweight recycled construction makes carrying and storing the stackable chair effortless. Thanks to an innovative ergonomic design and floating backrest technology, Cinto® supports the sitter’s lower back, offering automatic lumbar support unlike any other stackable office chair

Model numbers for Cinto® begin with ‘C1’ and ‘C2’.

The model in this LCA has the following features; fixed arms, casters, and fourtis seat pads. For this report, the most popular configuration options were chosen. Data availability in the Ecoinvent database was also a factor in configuration selection.

Figure 1: Product Specifications

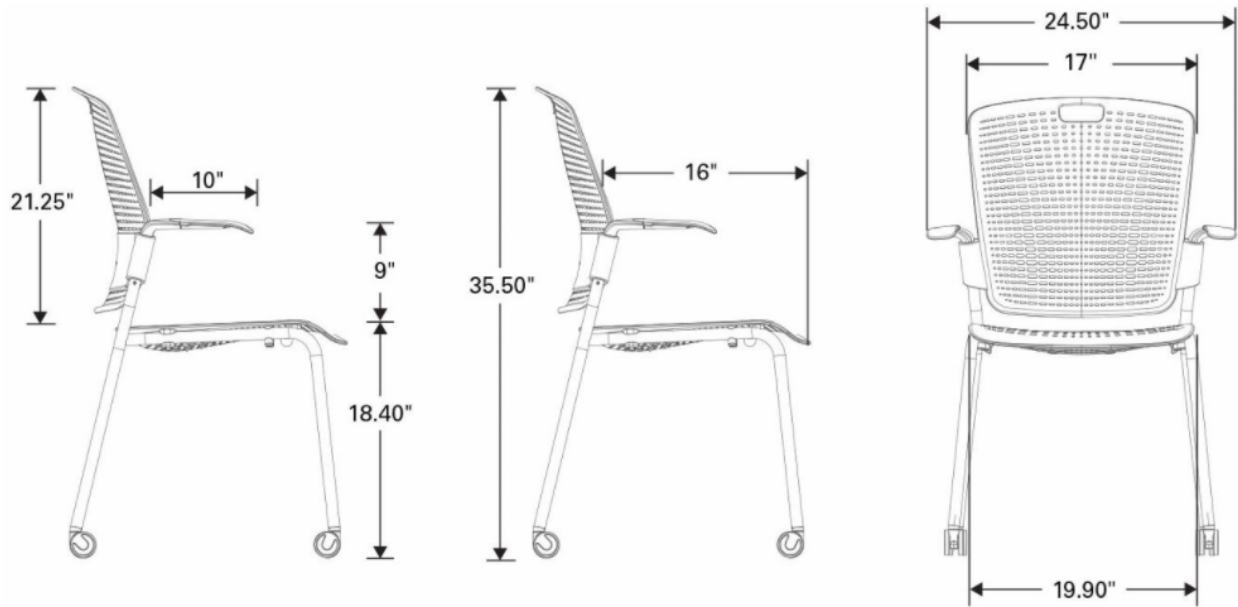

3.2.2 Technical Data

Table 1: Technical Details	
Sustainability certification	Declare: HSC-0014
	ANSI/BIFMA LEVEL® 3: SCS-SCF-05108
	HPD Label: Cinto
VOC emission	Indoor Advantage Gold: SCS-IAQ-05426

3.3 SYSTEM BOUNDARY

For full cradle-to-grave analysis, the upstream system boundary includes the full cradle-to-gate supply chains of all inputs beginning with material extraction and ending with final assembly of the product by Humanscale. The downstream system boundary begins with shipping of the product to the customer and terminates with product disposal which follows the solid waste treatment percentages of the most current version of the USEPA Municipal Solid Waste data for North America.

Table 2: Summary of Included Life Cycle Stages			
Module Name	BIFMA Seating PCR Life Cycle Stage Name	Analysis Period	Summary of Included Elements
Cinto MatExtract	Material Acquisition and Pre-processing	2019	Raw material extraction, transportation and refining including packaging as defined by secondary data.
Cinto MatTrans	Production (Manufacturing / Assembly)	2019	Manufacturing of components.
Cinto Trspt to HS	Production (Manufacturing / Assembly)	2019	Transportation of product components to Humanscale. Primary data is used.
Assembly	Production (Manufacturing / Assembly)	2019	Final assembly and packing at Humanscale facility. Primary data is used for electricity, natural gas and waste.
Cinto Trspt to Cust	Distribution, storage, and use	2019	Transportation to customer. Farthest shipping distance via freight truck is assumed.
Chair Maintenance	Distribution, storage, and use	2019	Cleaning of product.
Cinto EOL Trspt	End of life	2019	Transportation of product and product packaging to disposal facility.
Cinto EOL Disposal	End of Life	2019	Landfilling and incinerating of packaging and product parts.

Figure 2: System Boundary Diagram shows the full scope of the model which has been developed using primary and secondary data. All secondary data used in the model have multiple inputs from the ecoinvent database, and ultimately the full system (with foreground and background data) contains thousands of unit processes.

The system model includes production of raw materials, as well as all inputs of energy, inbound transport, and waste, outbound transportation to customer, use phase, and end of life including transportation and treatment of waste. Water is not used in the final assembly of Cinto® except for the production of the seat pad which is done by Humanscale with harvested rain water on site. The model assumes no city water use for final assembly.

Figure 2: System Boundary Diagram

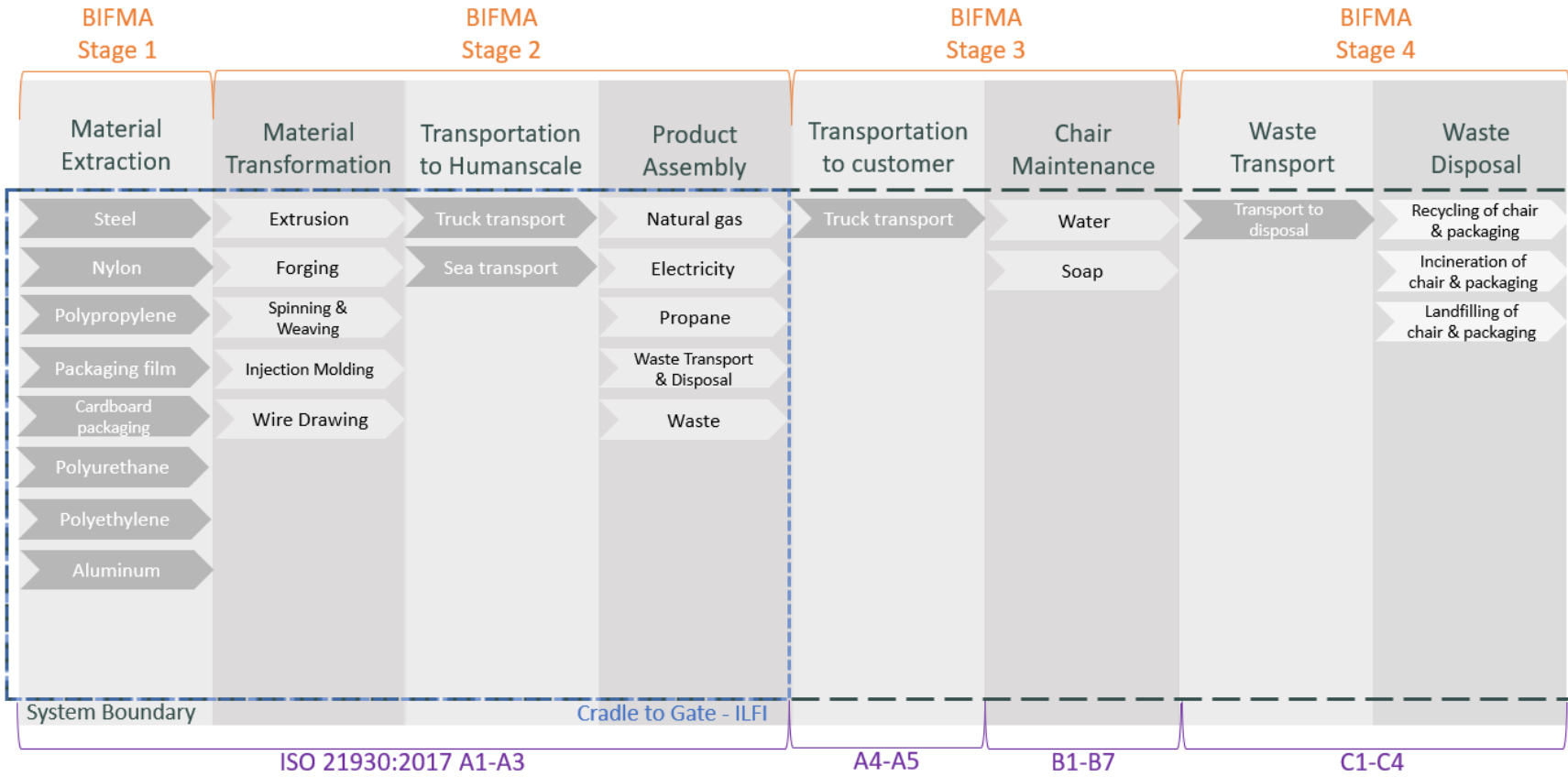

3.4 MATERIAL ACQUISITION AND PRE-PROCESSING STAGE

This stage includes raw material extraction, transportation to suppliers’ facilities, material refining including:

- Material extraction including scrap material
- Waste created during material processing, including the transportation of the waste created to landfill or recycling facility
- Material primary processing
- Interfacility transportation
- Materials used in packaging of the final product
- Transportation to the production stage

Table 3: Material Composition (grams)	
	Cinto
Plastic	2,423.16
Aluminum	388.59
Steel	3,028.85
Packaging	7,017.17
Other / Omitted	120.27
Total	12,978.03

In this phase, primary data was used for the amount of scrap generated during each process. Humanscale has gathered scrap information from first-tier suppliers. This material has been accounted for in Section 3.4. For waste generation and transportation, default values within the ecoinvent dataset were used.

For transportation to the production stage, default values in the ecoinvent database were used.

3.5 PRODUCTION

This stage includes manufacturing of main parts and components, transportation to Humanscale location, final assembly and packaging, including:

- Manufacturing of main furniture components from basic raw materials
- Transportation to Humanscale’s factory gate for assembly
- Transportation between Humanscale facilities, if applicable
- Product assembly, including the use of ancillary materials necessary for production, if applicable
- Product packaging
- Waste creation and processing
- Energy inputs

No additional preparation of the final product, including forming, surface treatment, machining and/or other processes occurs.

In this phase, primary data for waste material transportation was calculated using the PCR required default value of 32 kilometers (20 miles) since primary data was not available. For secondary data, waste transportation values were embedded in the LCA dataset used.

Waste generated at Humanscale facilities were based on primary data. For secondary data, waste destination parameters were embedded within the datasets used.

There are no additional inputs beyond what has been accounted for in the product's raw materials that are required for the assembly and install of the product.

3.6 DISTRIBUTION, STORAGE, AND USE

This stage includes all materials, energy and waste related to product transport to customer and chair use/maintenance.

- Transportation from manufacturing gate to customer
- Product maintenance (cleaning with mild soap and water)

Except in rare cases, the product is shipped direct to customer. As such, storage is not relevant. Additionally, there is no energy or additional inputs required for operation and use and the product does not change the operational efficiency of the building. This same statement can be said for water. Repair and refurbishment happens infrequently and did not need to be accounted for.

Transportation mode and distances in this phase was based on primary data. The value utilized represents the furthest customer from the assembly location. The average farthest shipping distance for all final assembly locations is 3,463 kilometers.

3.7 END OF LIFE MANAGEMENT

This stage includes transportation of the product and packaging to the end of life facility. Even though Humanscale products are highly recyclable and come with disassembly instructions, the product is assumed to be landfilled, incinerated and recycled based on the BIFMA PCR and EPA Recycling Rates for North America. Collection of end of life product and packaging distances are based on the current USEPA WARM Model per the PCR. All waste materials are assumed to be disposed of in the North America for products assembled in North America facilities. North American EPA data was used for end of life modeling in Dublin as well in absence of European-specific hauling distances and recycling rates.

Geographic specificity of the dataset used to represent product landfilling was global in nature.

Product	Material Type	Weight (grams)	Recycling Rate*	Weight Recycled (grams)	Weight Incinerated (grams)**	Weight Landfilled (grams)**
Cinto®	Plastic	2,473.16	8.37%	206.97	1,812.95	453.24
	Paperboard	6,967.17	65.92%	4,592.45	1,899.78	474.94
	Aluminum	388.59	16.19%	62.90	260.55	65.14
	Ferrous metals	3,028.85	32.66%	989.31	1,631.63	407.91

*Recycling rates from the 2017 EPA Sustainable Materials Management (SMM) – Materials and Waste Management in the United States Key Facts and Figures.

** Per the PCR, 80% of the material not recycled should be modeled using landfill and 20% using incineration.

3.8 CUT-OFF CRITERIA

This LCA follows the cut-off criteria required by the BIFMA PCR for Seating, which allows flows less than 1% to be omitted if their omission is justified. Cumulatively all mass and energy omitted cannot exceed 5%.

For this study, Humanscale attempted to include all known mass and energy flows. Some flows were omitted due to data quality restrictions. Specially, the following flows were omitted:

- The system model omits powder coating, colorant, and painting totaling 120.27 grams or 0.927% of the product weight.

3.9 ALLOCATION PROCEDURES

For primary data, mass allocation was used to model waste and energy inputs. For this, the total weight of the chair was divided by the total weight of all products produced in the Humanscale facility during the 2019 calendar year to proportionately allocate waste and energy. For background processes we used the Ecoinvent database, version 3.6 APOS, which implements an attributional modeling approach; “APOS” refers to “allocation at the point of substitution.”

3.10 DATA QUALITY REQUIREMENTS

3.10.1 Geographical Coverage

Final manufacturing of the product occurs in three Humanscale facilities in North America & Europe, and the product is shipped to customers globally. For the purpose of this report, three models have been created to represent the impacts of the Cinto® chair specific to its final assembly location and their supply chains.

Unites States

220 Circle Dr N,
Piscataway, NJ 08854

3371 East Central Avenue
Fresno, CA 93725

Ireland

IDA Industrial Estate Poppintree
Finglas
Dublin 11

3.10.2 Time Coverage

The study is meant to reflect current conditions, using primary data from the most recent full calendar year available, 2019.

3.10.3 Technical Coverage

Primary data was retrieved from Humanscale utility and waste hauling bills from the most current complete calendar year (2019), is site-specific and considered of good quality. The energy used in manufacturing includes the overhead energy (lighting, heating, etc.) of the entire facility. Sub-metering was not available to extract process energy use from the total energy use. Sub-metering would improve the technological coverage of data quality.

For secondary data, we use the most current version of the Ecoinvent database, version 3.6.

In cases where proxy data must be used, we compare the available options and use the most conservative option (the one which yields higher cradle-to-gate impacts on one or more of the three impact categories indicated in the goal and scope). Secondary data used in this study are listed in Table 5 below. In general, secondary data was of overall good quality, however regional specificity was lacking. This was due to the lack of availability of regionally specific data in the ecoinvent database. No flows were knowingly excluded from the study.

Dataset	Source	Time Coverage	Geographical Coverage	Technical Coverage	Overall Representativeness
market for aluminium, cast alloy	Ecoinvent	Within 5-year period	GLO	Appropriate technology	Great, appropriate technology but not exact geography
market for nylon 6	Ecoinvent	Within 5-year period	GLO	Appropriate technology	Great, appropriate technology but not exact geography
market for polyethylene terephthalate, granulate, amorphous	Ecoinvent	Within 5-year period	GLO	Appropriate technology	Great, appropriate technology but not exact geography
packaging film, low density polyethylene	Ecoinvent	Within 5-year period	GLO	Appropriate technology	Great, appropriate technology but not exact geography
market for polypropylene, granulate	Ecoinvent	Within 5-year period	GLO	Appropriate technology	Great, appropriate technology but not exact geography
market for polyurethane, flexible foam	Ecoinvent	Within 5-year period	GLO	Appropriate technology	Great, appropriate technology but not exact geography
market for polyurethane, rigid foam	Ecoinvent	Within 5-year period	GLO	Used as proxy for TPU	Good
textile, non-woven polypropylene	Ecoinvent	Within 5-year period	RoW	Used as proxy for nylon textile production	Good
market for steel, unalloyed	Ecoinvent	Within 5-year period	ROW	Appropriate technology	Great, appropriate technology but not exact geography
corrugated board box	Ecoinvent	Within 5-year period	RoW	Appropriate technology	Great, appropriate technology but not exact geography

market for forging, steel	Ecoinvent	Within 5-year period	GLO	Appropriate technology	Great, appropriate technology but not exact geography
market for impact extrusion of aluminum	Ecoinvent	Within 5-year period	GLO	Appropriate technology	Great, appropriate technology but not exact geography
market for impact extrusion of steel	Ecoinvent	Within 5-year period	GLO	Appropriate technology	Great, appropriate technology but not exact geography
market for injection moulding	Ecoinvent	Within 5-year period	GLO	Appropriate technology	Great, appropriate technology but not exact geography
weaving, synthetic fibre	Ecoinvent	Within 5-year period	GLO	Appropriate technology	Great, appropriate technology but not exact geography
market for wire drawing, steel	Ecoinvent	Within 5-year period	GLO	Appropriate technology	Great, appropriate technology but not exact geography
transport, freight, lorry 16-32 metric ton, EURO4	Ecoinvent	Within 5-year period	GLO	Appropriate technology	Excellent
transport, freight, sea, transoceanic tanker	Ecoinvent	Within 5-year period	GLO	Appropriate technology	Excellent
market for electricity, low voltage	Ecoinvent	Within 5-year period	Ireland	Appropriate technology	Excellent
market for electricity, low voltage	Ecoinvent	Within 10-year period	RFC	Appropriate technology	Excellent
market for electricity, low voltage	Ecoinvent	Within 10-year period	WECC, US only	Appropriate technology	Excellent
municipal solid waste	Ecoinvent	Within 5-year period	RoW	Appropriate technology	Good, appropriate technology but not exact geography
municipal waste collection service by 21 metric ton lorry	Ecoinvent	Within 5-year period	RoW	Appropriate technology	Great, appropriate technology but not exact geography
market for natural gas, low pressure	Ecoinvent	Within 5-year period	RoW	Appropriate technology	Great, appropriate technology but not exact geography
natural gas production, propane	Ecoinvent	Within 5-year period	RoW	Appropriate technology	Great, appropriate technology but not exact geography
soap	Ecoinvent	Within 5-year period	RoW	Used as proxy for mild soap	Good, closest technology, not exact geography
market for tap water	Ecoinvent	Within 5-year period	RoW	Appropriate technology	Great, appropriate technology but not exact geography
treatment of scrap aluminium, municipal incineration	Ecoinvent	Within 5-year period	RoW	Appropriate technology	Great, appropriate technology but not exact geography
treatment of waste aluminium, sanitary landfill	Ecoinvent	Within 5-year period	RoW	Appropriate technology	Great, appropriate technology but not exact geography
treatment of waste paperboard, municipal incineration	Ecoinvent	Within 5-year period	RoW	Appropriate technology	Great, appropriate technology but not exact geography

treatment of waste paperboard, sanitary landfill	Ecoinvent	Within 5-year period	RoW	Appropriate technology	Great, appropriate technology but not exact geography
treatment of scrap steel paperboard, municipal incineration	Ecoinvent	Within 5-year period	RoW	Appropriate technology	Great, appropriate technology but not exact geography
treatment of scrap steel paperboard, sanitary landfill	Ecoinvent	Within 5-year period	RoW	Appropriate technology	Great, appropriate technology but not exact geography

3.10.4 Treatment of Missing Data

We leave upstream supply chain electricity modeling (embedded within the background database) unaltered. The recycled content amounts are supplied to Humanscale directly from the vendor of each material. We did not have primary data on customer use, however it was assumed that the customer will wash their Cinto® chair in accordance with Humanscale’s Cleaning Instructions for Humanscale Seating Products. All Humanscale products come with Disassembly Instructions and are highly recyclable, however per the PCR, the model assumes the product is landfilled, incinerated and recycled based on the current USEPA WARM Model.

4 LIFE CYCLE INVENTORY ANALYSIS

4.1 DATA COLLECTION AND CALCULATION PROCEDURES

Primary data was used for all bill-of-material items, as well as all inputs of energy, inbound transport, waste, and outbound transportation.

Primary data were obtained from the following sources. Solidworks CAD models were used to provide a full bill of materials, listing each part, it’s material, and part weight. Infor, Humanscale’s ERP system, which is used for ordering components, provided the name of supplier, their address, and common shipping method for all components ordered. Trucking distances were calculated using Google Maps, and ocean freight distances were estimated by using SeaRoutes.com. Amount of scrap was provided by the suppliers directly or estimated. Energy use in the facility of final assembly was calculated based on primary data.

Neither normalization nor weighting have been used in this study. Results are presented at the midpoint level. We include the ISO-required LCIA disclaimer here: “ISO 14044 does not specify any specific methodology or support the underlying value choices used to group the impact categories. Any value-choices and judgments embedded within the grouping procedures are the sole responsibilities of the commissioner of the study (e.g. government, community, organization, etc.)”

4.2 LIMITATIONS OF THE STUDY

LCA is a method used to assess potential rather than actual impacts. Consistent with our Goal and Scope, we obtained primary data for the final manufacturing step, and used secondary data for the background processes including the supply chain processes.

Due to the assumptions and value choices listed above, these do not reflect real-life scenarios and hence they cannot assess actual and exact impacts, but only potential environmental impacts. The results presented here should not be used as-is in a comparative assessment with competing products.

Some limitations to the study have been identified as follows:

- A significant limitation of the study was the availability of geographically appropriate datasets. More accurate datasets would have improved the accuracy of the study.
- Availability of primary data for suppliers’ energy use, waste and transportation values would have been ideal but was not available.

5 LIFE CYCLE IMPACT ASSESSMENT

5.1 SELECTION OF IMPACT PARAMETERS

Environmental Impacts were calculated using the OpenLCA software platform. Impact results have been calculated using both TRACI 2.1 and ReCiPe 2016 Midpoint (H) characterization factors. This LCA uses TRACI 2.1 per the requirements of the BIFMA PCR. ReCiPe 2016 Midpoint (H) is also used as it is required by ILFI. Specific impact parameters were selected based on the requirements of the ILFI Living Product Challenge Certification requirements and requirements listed for LCA in the LEED V4.1 standard. Per ISO 14040/44: LCIA results are relative expressions and do not predict impacts on category endpoints, the exceeding of thresholds, safety margins or risks.

Table 6: Impact Parameters			
Requirement of	Abbreviation	Parameter	Unit
TRACI 2.1			
BIFMA	AP	Acidification Potential	kg SO2 eq
BIFMA	EP	Eutrophication Potential	kg N eq
BIFMA / ILFI	GWP	Global Warming Potential	kg CO2 eq
BIFMA	OD	Ozone Depletion	kg CFC-11 eq
BIFMA	Smog	Smog	kg O3 eq
ReCiPe 2016 Midpoint (H)			
ILFI	WC	Water Consumption	m3
ILFI	FS	Fossil Resource Scarcity	kg oil eq

5.2 LCA RESULTS

All results are given per functional unit as stated in in Section 3.1, which is one chair to provide seating to one individual.

5.2.1 Cinto®

Table 7: Cinto Piscataway LCA Results						
Method	Impact Category	LPC Boundary		Distribution, storage, and use	End of Life	Cradle to Grave Total
		Material Acquisition and Pre-processing	Production (Manufacturing / Assembly)			
TRACI 2.1	AP (kg SO2 eq)	1.29E-01	3.64E-02	3.57E-02	4.21E-03	2.05E-01
	EP (kg N eq)	8.96E-02	3.40E-02	1.20E-02	3.90E-02	1.75E-01
	GWP (kg CO2 eq)	2.94E+01	9.03E+00	8.40E+00	4.09E+00	5.09E+01
	OD (kg CFC 11 eq)	1.64E-06	1.06E-06	1.89E-06	1.59E-07	4.75E-06
	Smog (kg O3 eq)	1.64E+00	4.97E-01	8.16E-01	1.02E-01	3.05E+00
ReCiPe 2016 Midpoint (H)	WC (m3)	2.89E-01	6.50E-02	3.17E-02	5.48E-03	3.91E-01
	FS (kg oil-Eq)	9.23E+00	2.81E+00	2.76E+00	2.18E-01	1.50E+01

Table 8: Cinto Fresno LCA Results

Method	Impact Category	LPC Boundary		Distribution, storage, and use	End of Life	Cradle to Grave Total
		Material Acquisition and Pre-processing	Production (Manufacturing / Assembly)			
TRACI 2.1	AP (kg SO2 eq)	1.29E-01	4.14E-02	3.00E-02	4.21E-03	2.05E-01
	EP (kg N eq)	8.96E-02	3.07E-02	1.05E-02	3.90E-02	1.70E-01
	GWP (kg CO2 eq)	2.94E+01	9.42E+00	7.05E+00	4.09E+00	4.99E+01
	OD (kg CFC 11 eq)	1.64E-06	1.23E-06	1.57E-06	1.59E-07	4.61E-06
	Smog (kg O3 eq)	1.64E+00	6.48E-01	6.80E-01	1.02E-01	3.07E+00
ReCiPe 2016 Midpoint (H)	WC (m3)	2.89E-01	6.44E-02	2.93E-02	5.48E-03	3.88E-01
	FS (kg oil-Eq)	9.23E+00	2.90E+00	2.30E+00	2.18E-01	1.46E+01

Table 9: Cinto Dublin LCA Results

Method	Impact Category	LPC Boundary		Distribution, storage, and use	End of Life	Cradle to Grave Total
		Material Acquisition and Pre-processing	Production (Manufacturing / Assembly)			
TRACI 2.1	AP (kg SO2 eq)	1.29E-01	3.63E-02	3.69E-02	4.21E-03	2.06E-01
	EP (kg N eq)	8.96E-02	3.09E-02	1.23E-02	3.90E-02	1.72E-01
	GWP (kg CO2 eq)	2.94E+01	9.18E+00	8.67E+00	4.09E+00	5.13E+01
	OD (kg CFC 11 eq)	1.64E-06	1.07E-06	1.95E-06	1.59E-07	4.82E-06
	Smog (kg O3 eq)	1.64E+00	5.27E-01	8.42E-01	1.02E-01	3.11E+00
ReCiPe 2016 Midpoint (H)	WC (m3)	2.89E-01	6.33E-02	3.22E-02	5.48E-03	3.89E-01
	FS (kg oil-Eq)	9.23E+00	2.82E+00	2.85E+00	2.18E-01	1.51E+01

5.3 TOP 5 PROCESSES CONTRIBUTING TO ENERGY CONSUMPTION

In connection with the Living Product Challenge Imperative 06 Energy Footprint, the table below presents the five processes that make the largest contributions to the cradle-to-gate (as defined by the ILFI) energy footprint of Cinto®. From the results below, it is clear that aluminum used in the chair armrests and polypropylene used for the chair back and seat are the largest contributors. Furthermore, the relative impacts of the top contributors are roughly the same across all assembly locations.

Table 10: Top 5 Processes Contributing to Energy Consumption ReCiPe 2016 Midpoint (H)				
	Final Assembly Location	Process	%	Kg oil-Eq
Cinto®	Piscataway, NJ	market for aluminum, cast alloy	21.89%	2.64E+00
		market for polypropylene, granulate	21.82%	2.63E+00
		corrugated board box production	10.20%	1.23E+00
		market for injection moulding	8.06%	9.70E-01
		market for forging, steel	7.84%	9.45E-01
	Fresno, CA	market for aluminum, cast alloy	21.74%	2.64E+00
		market for polypropylene, granulate	21.67%	2.63E+00
		corrugated board box production	10.13%	1.23E+00
		market for injection moulding	8.00%	9.70E-01
		market for forging, steel	7.79%	9.45E-01
	Dublin, IE	market for aluminum, cast alloy	21.87%	2.64E+00
		market for polypropylene, granulate	21.80%	2.63E+00
		corrugated board box production	10.19%	1.23E+00
		market for injection moulding	8.05%	9.70E-01
		market for forging, steel	7.84%	9.45E-01

5.4 TOP 5 PROCESSES CONTRIBUTING TO CARBON FOOTPRINT

In connection with the Living Product Challenge Impetrative 14 Net Positive Carbon, the table below presents the five processes that make the largest contributions to the cradle-to-gate (as defined by the ILFI) carbon footprint of Cinto®. From the results below, it is clear aluminum the largest contributor by far. Furthermore, the relative impacts of the top contributors are roughly the same across all assembly locations.

Table 11: Top 5 Processes Contributing to Carbon Footprint TRACI 2.1				
	Final Assembly Location	Process	%	Kg CO2-Eq
Cinto®	Piscataway, NJ	market for aluminum, cast alloy	31.34%	1.20E+01
		corrugated board box production	11.11%	4.27E+00
		market for steel, unalloyed	10.48%	4.02E+00
		market for polypropylene, granulate	8.89%	3.41E+00
		market for forging, steel	8.54%	3.28E+00
	Fresno, CA	market for aluminum, cast alloy	31.02%	1.20E+01
		corrugated board box production	10.99%	4.27E+00
		market for steel, unalloyed	10.37%	4.02E+00
		market for polypropylene, granulate	8.80%	3.41E+00
		market for forging, steel	8.45%	3.28E+00
	Dublin, IE	market for aluminum, cast alloy	31.21%	1.20E+01
		corrugated board box production	11.06%	4.27E+00
		market for steel, unalloyed	10.44%	4.02E+00
		market for polypropylene, granulate	8.85%	3.41E+00
		market for forging, steel	8.50%	3.28E+00

5.5 TOP 5 PROCESS CONTRIBUTING TO WATER DEPLETION

In connection with the Living Product Challenge Impetrative 04 Water Footprint, the table below presents the five processes that make the largest contributions to the cradle-to-gate (as defined by the ILFI) water footprint of Cinto®. From the results below, aluminum and the cardboard packaging are significant contributors. Furthermore, the relative impacts of the top contributors are roughly the same across all assembly locations.

Table 12: Top 5 Processes Contributing to Water Consumption ReCiPe 2016 Midpoint (H)				
	Final Assembly Location	Process	%	m3
Cinto®	Piscataway, NJ	market for aluminum, cast alloy	24.08%	8.51E-02
		corrugated board box production	17.04%	6.03E-02
		market for polyurethane, rigid foam	11.28%	3.99E-02
		market for injection moulding	9.70%	3.43E-02
		market for polypropylene, granulate	9.09%	3.21E-02
	Fresno, CA	market for aluminum, cast alloy	24.12%	8.51E-02
		corrugated board box production	17.07%	6.03E-02
		market for polyurethane, rigid foam	11.30%	3.99E-02
		market for injection moulding	9.71%	3.43E-02
		market for polypropylene, granulate	9.10%	3.21E-02
	Dublin, IE	market for aluminum, cast alloy	24.20%	8.51E-02
		corrugated board box production	17.13%	6.03E-02
		market for polyurethane, rigid foam	11.33%	3.99E-02
		market for injection moulding	9.74%	3.43E-02
		market for polypropylene, granulate	9.13%	3.21E-02

5.6 SENSITIVITY ANALYSIS

Factor	BIFMA Life Cycle Stage Name	Model	GWP (kg CO2 eq)		% Change
			Original	After Change	
Shipping Distance: half the mileage. (Original model assumes farthest shipping distance to customer)	Distribution, storage, and use	Cinto	5.09E+01	4.69E+01	-7.84%
Allocation method: economic instead of mass allocation	Production (Manufacturing / Assembly) & Distribution, storage, and use	Cinto	5.09E+01	5.00E+01	-1.84%
Electricity used in assembly: GLO instead of RFC electrical grid.	Production (Manufacturing / Assembly) & Distribution, storage, and use	Cinto	5.09E+01	5.10E+01	0.27%
Electricity used in assembly: reduced by 10%	Production (Manufacturing / Assembly) & Distribution, storage, and use	Cinto	5.09E+01	5.08E+01	-0.18%
Waste shipping: half the distance at end of life	End of Life	Cinto	5.09E+01	5.06E+01	-0.51%

6 INTERPRETATION

As shown in Section 5.3, 5.4 and 5.5, the top five processes within the cradle-gate (as defined by the International Living Future Institute) life cycle stages of the Cinto® chair, that rank highest in terms of their total contributions to carbon, energy and water consumption, all take place during the Extraction and Pre-Processing life cycle stage.

The extraction and preprocessing of aluminum used in the armrests is the main contributor to the products' cradle to gate energy, carbon and water footprint. Unlike other materials in this chair, the aluminum does not come from recycled sources. On average, aluminum is responsible for 21.83% of the product's energy footprint, 31.19% of its carbon footprint and 24.13% of its water footprint. Using recycled aluminum would have a beneficial impact to the product's cradle to gate footprint. Using recycled polypropylene would also have a beneficial impact in the product footprint, specifically it's energy footprint. Polypropylene is used primarily in the product's seat and back and contributes to 21.76% of the energy footprint of Cinto® on average.

The models in this report assume that the chair is being shipped to the furthest customer relative to their manufacturing location. In the Sensitivity Analysis, the shipping distance was reduced by 50%

which had a significant impact to the Global Warming Potential of the product. The results show a reduction of 7.84% in the products' cradle to grave carbon footprint when being shipped to a customer half as far.

The Sensitivity Analysis shows that the model is not sensitive to the Allocation Method used; mass vs economic. The models in this report use mass allocation to account for their contribution to the waste, water, and energy inputs during assembly at Humanscale's manufacturing location. The analysis shows only a 1.84% benefit to the Global Warming Potential for Cinto®, when using an economic allocation method over a mass allocation method.

Limitations of the study include the following:

Availability of primary data for suppliers' energy use, waste generated, and transportation values would have been ideal but was not available. Using primary data could have adjusted the results slightly.

In general, secondary data was of overall good quality, however the data was of poor geographic coverage. This was due to the lack of availability of regionally-specific data in the ecoinvent database. For many inputs, Global averages were used. In section 5.6, the Sensitivity Analysis compares the Global Warming Potential of the model when using Global geographical coverage for electricity instead of an electricity input specific to the manufacturing location. Using Global electricity increased the total impacts for Cinto® by 0.27%. Although the model was not sensitive to the geographical coverage of the electricity input, it is possible that having regional datasets for each of the inputs in which Global averaged were used could have impacted the results as whole.

7 WORKS CITED

ISO (the International Organization for Standardization) ISO 14040 Environmental management — Life cycle assessment — Principles and framework 2006

ISO (the International Organization for Standardization) ISO 14044 Environmental management — Life cycle assessment — Requirements and guidelines 2006

RIVM, Radboud University, Norwegian University of Science and Technology and PRé Consultants ReCiPe 2016 Midpoint (H)

Sea Routes. [online] Available from www.searoutes.com

U.S. Environmental Protection Agency (2017) Waste Reduction Model (WARM). Available from http://www.epa.gov/climatechange/wycd/waste/calculators/Warm_home.html

U.S. Environmental Protection Agency Tool for the Reduction and Assessment of Chemical and Other Environmental Impacts (TRACI 2.1)

Wernet, G., Bauer, C., Steubing, B., Reinhard, J., Moreno-Ruiz, E., and Weidema, B., 2016. The ecoinvent database version 3 (part I): overview and methodology. *The International Journal of Life Cycle Assessment*, [online] 21(9), pp.1218–1230. Available at: <<http://link.springer.com/10.1007/s11367-016-1087-8>> [Accessed 19 16 2020].

APPENDIX B. VERIFICATION DOCUMENTS

LCA VERIFICATION REPORT

Client:

Humanscale

Name of Study:

Cinto® Chair Life Cycle Assessment

Products Included in LCA Report:

Cinto® Guest/ Side Chair

Review Completed:

November 17, 2020



TABLE OF CONTENTS

TABLE OF CONTENTS	I
CONFORMANCE STATEMENT	II
ISO 14044:2006	4
COMPLIANCE TO LIVING PRODUCT CHALLENGE 2.0 LCA-BASED REQUIREMENTS	10
COMPLIANCE TO LEED V4.1 LCA-BASED REQUIREMENTS	12
BIFMA PCR FOR SEATING: UNCPC 3811 VERSION 3	13
LCA MODEL REVIEW CHECKLIST	17

EXTENSION STATEMENT

Humanscale has requested for an extension on the Cinto Chair LCA. They are currently in the process of updating their data and LCA. The projected changes are not believed to have a significant change in current results.

Given this, Humanscale's LCA is being granted an extension of 6-months.

Previous expiration: November 16, 2023

New expiration: May 16, 2024

CONFORMANCE STATEMENT

In November of 2020, WAP Sustainability Consulting commenced an LCA critical review and verification of the Life Cycle Assessment of the Cinto Chair. The Life Cycle Assessment (LCA) was commissioned by Humanscale. Stephanie Richardson from Humanscale was the lead LCA practitioner.

The LCA was conducted as a cradle-to-grave assessment with the goal that the LCA would be submitted for Living Product Challenge (LPC) certification and LEED 2.1 MRc point contribution. After several rounds of reviews and modifications, the critical review was finalized in November 2020.

The review process was conducted over a week and included couple of rounds of comments and responses. WAP Sustainability reviewed the LCA to ISO14040/44 and BIFMA PCR for Seating: UNCPC 3811. In addition to the LCA report, primary data and calculation methods were provided to and reviewed by WAP Sustainability. The LCA model, which was created in OpenLCA, was reviewed as well. All data that was requested by WAP Sustainability was provided in a timely manner.

Critical inputs and assumptions were discussed in depth. Concerns related to these critical assumptions were alleviated through additional information provided by both the manufacture and the LCA practitioner. Additionally, a sensitivity analysis was conducted to compare allocation methods, dataset choices, and shipping and waste assumptions.

The full LCA review checklists are included in the following pages of the report. In summary, the report is a well-written LCA that does not exclude material impacts that would be expected within the life cycle of Humanscale's Cinto Chair. It is our opinion that the LCA study and LCA report were found to be in compliance with LCA to ISO14040/44. Additionally, the requirements for compliance with ILFI's Living Product Challenge and USGBC LEED 2.1 Material Resources Credits have been met.



W. Brad McAllister
Director
WAP Sustainability Consulting



Manasa Rao, LCACP
LCA Reviewer
WAP Sustainability Consulting

ISO 14044:2006

	Element	Applicability	Conformance Status	Review Comments <small>(Reviewer Comments in Black, LCA Practitioner Comments in Red)</small>	Approval Date
1	Review of General Elements of Report				
1.1	Name of commissioner of study.	<input checked="" type="checkbox"/> Requirement <input type="checkbox"/> Not Applicable	<input checked="" type="checkbox"/> Conformance <input type="checkbox"/> Non-Conformance	Section 2.1	11/17/2020
1.2	Name of practitioner of study.	<input checked="" type="checkbox"/> Requirement <input type="checkbox"/> Not Applicable	<input checked="" type="checkbox"/> Conformance <input type="checkbox"/> Non-Conformance	Section 2.1	11/17/2020
1.3	Date study was conducted.	<input checked="" type="checkbox"/> Requirement <input type="checkbox"/> Not Applicable	<input checked="" type="checkbox"/> Conformance <input type="checkbox"/> Non-Conformance	Section 2.2	11/17/2020
1.4	Does study include a Goal and Scope section?	<input checked="" type="checkbox"/> Requirement <input type="checkbox"/> Not Applicable	<input checked="" type="checkbox"/> Conformance <input type="checkbox"/> Non-Conformance	Section 2.3 Confirmed appropriate in interviews with practitioner.	11/17/2020
1.5	Does study include an Inventory Analysis section?	<input checked="" type="checkbox"/> Requirement <input type="checkbox"/> Not Applicable	<input checked="" type="checkbox"/> Conformance <input type="checkbox"/> Non-Conformance	Section 4	11/17/2020
1.6	Does study include an Impact Assessment Section?	<input checked="" type="checkbox"/> Requirement <input type="checkbox"/> Not Applicable	<input checked="" type="checkbox"/> Conformance <input type="checkbox"/> Non-Conformance	Section 5	11/17/2020
1.7	Does the study include an interpretation of results?	<input checked="" type="checkbox"/> Requirement <input type="checkbox"/> Not Applicable	<input checked="" type="checkbox"/> Conformance <input type="checkbox"/> Non-Conformance	Section 6.	11/17/2020
1.8	Does the study include a discussion on limitations?	<input checked="" type="checkbox"/> Requirement <input type="checkbox"/> Not Applicable	<input checked="" type="checkbox"/> Conformance <input type="checkbox"/> Non-Conformance	Section 4.2	11/17/2020
1.9	Does the study include a data quality assessment? Are these sufficient to enable goal and scope to be met?	<input checked="" type="checkbox"/> Requirement <input type="checkbox"/> Not Applicable	<input checked="" type="checkbox"/> Conformance <input type="checkbox"/> Non-Conformance	Section 3.10 Limitations and data quality discussed with practitioner throughout the project.	11/17/2020
1.10	Does the study include a statement on ISO compliance?	<input checked="" type="checkbox"/> Requirement <input type="checkbox"/> Not Applicable	<input checked="" type="checkbox"/> Conformance <input type="checkbox"/> Non-Conformance	Section 2.6	11/17/2020

1.11	Goal clearly defined and consistent with intended application?	<input checked="" type="checkbox"/> Requirement <input type="checkbox"/> Not Applicable	<input checked="" type="checkbox"/> Conformance <input type="checkbox"/> Non-Conformance	Section 2.4	11/17/2020
1.12	Reason for study stated?	<input checked="" type="checkbox"/> Requirement <input type="checkbox"/> Not Applicable	<input checked="" type="checkbox"/> Conformance <input type="checkbox"/> Non-Conformance	Section 2.4	11/17/2020
1.13	Intended application stated?	<input checked="" type="checkbox"/> Requirement <input type="checkbox"/> Not Applicable	<input checked="" type="checkbox"/> Conformance <input type="checkbox"/> Non-Conformance	Section 2.4	11/17/2020
1.14	Function of product system clearly described.	<input checked="" type="checkbox"/> Requirement <input type="checkbox"/> Not Applicable	<input checked="" type="checkbox"/> Conformance <input type="checkbox"/> Non-Conformance	Section 3.1 – one unit of seating to seat one individual, maintained for a 10-year period	11/17/2020
1.15	Functional unit adequately described and appropriate?	<input checked="" type="checkbox"/> Requirement <input type="checkbox"/> Not Applicable	<input checked="" type="checkbox"/> Conformance <input type="checkbox"/> Non-Conformance	Section 3.1 – one unit of seating to seat one individual, maintained for a 10-year period	11/17/2020
1.16	System boundary adequately described and appropriate?	<input checked="" type="checkbox"/> Requirement <input type="checkbox"/> Not Applicable	<input checked="" type="checkbox"/> Conformance <input type="checkbox"/> Non-Conformance	Section 3.3 – Defined in Section 3.3.	11/17/2020
1.18	Are allocation procedures described and appropriate?	<input checked="" type="checkbox"/> Requirement <input type="checkbox"/> Not Applicable	<input checked="" type="checkbox"/> Conformance <input type="checkbox"/> Non-Conformance	Section 3.9 – discussed with practitioner.	11/17/2020
1.18	Geographical coverage stated and appropriate?	<input checked="" type="checkbox"/> Requirement <input type="checkbox"/> Not Applicable	<input checked="" type="checkbox"/> Conformance <input type="checkbox"/> Non-Conformance	Yes, some limitations due to data but appropriate based on data availability.	11/17/2020
1.19	Is the cut-off criteria stated and appropriate?	<input checked="" type="checkbox"/> Requirement <input type="checkbox"/> Not Applicable	<input checked="" type="checkbox"/> Conformance <input type="checkbox"/> Non-Conformance	Section 3.8	11/17/2020
1.20	Are the impact categories described and appropriate?	<input checked="" type="checkbox"/> Requirement <input type="checkbox"/> Not Applicable	<input checked="" type="checkbox"/> Conformance <input type="checkbox"/> Non-Conformance	Section 5.1.	11/17/2020
1.21	Are the impact assessment and interpretation methods described and appropriate?	<input checked="" type="checkbox"/> Requirement <input type="checkbox"/> Not Applicable	<input checked="" type="checkbox"/> Conformance <input type="checkbox"/> Non-Conformance	Section 5.1.	11/17/2020
1.22	Source of background data stated and clear?	<input checked="" type="checkbox"/> Requirement <input type="checkbox"/> Not Applicable	<input checked="" type="checkbox"/> Conformance <input type="checkbox"/> Non-Conformance	Section 3.10.3	11/17/2020
1.23	Are the data quality requirements of background data described and appropriate?	<input checked="" type="checkbox"/> Requirement <input type="checkbox"/> Not Applicable	<input checked="" type="checkbox"/> Conformance <input type="checkbox"/> Non-Conformance	Section 3.10.3	11/17/2020

1.24	Source of foreground data stated and clear?	<input checked="" type="checkbox"/> Requirement <input type="checkbox"/> Not Applicable	<input checked="" type="checkbox"/> Conformance <input type="checkbox"/> Non-Conformance	Section 3.4, 3.5, 3.6.	11/17/2020
1.25	Are the data quality requirements of foreground data described and appropriate?	<input checked="" type="checkbox"/> Requirement <input type="checkbox"/> Not Applicable	<input checked="" type="checkbox"/> Conformance <input type="checkbox"/> Non-Conformance	Section 3 and in supplemental information provided by practitioner.	11/17/2020
1.26	Were assumptions and limitations adequately described?	<input checked="" type="checkbox"/> Requirement <input type="checkbox"/> Not Applicable	<input checked="" type="checkbox"/> Conformance <input type="checkbox"/> Non-Conformance	Section 4 and discussed with practitioner.	11/17/2020
1.27	Did the report include an appropriate statement on critical review?	<input checked="" type="checkbox"/> Requirement <input type="checkbox"/> Not Applicable	<input checked="" type="checkbox"/> Conformance <input type="checkbox"/> Non-Conformance	Section 2.7	11/17/2020
1.28	Is the report format described (i.e. table of contents, list of figures, etc)?	<input checked="" type="checkbox"/> Requirement <input type="checkbox"/> Not Applicable	<input checked="" type="checkbox"/> Conformance <input type="checkbox"/> Non-Conformance	Yes	11/17/2020
1.29	Were any additional functions of product system omitted? If so, were the reasons for the omission stated?	<input checked="" type="checkbox"/> Requirement <input type="checkbox"/> Not Applicable	<input checked="" type="checkbox"/> Conformance <input type="checkbox"/> Non-Conformance	No functions omitted.	11/17/2020
1.30	Did the review find that the justification to be appropriate?	<input checked="" type="checkbox"/> Requirement <input type="checkbox"/> Not Applicable	<input checked="" type="checkbox"/> Conformance <input type="checkbox"/> Non-Conformance	No functions omitted.	11/17/2020
1.31	Were unit processes described adequately?	<input checked="" type="checkbox"/> Requirement <input type="checkbox"/> Not Applicable	<input checked="" type="checkbox"/> Conformance <input type="checkbox"/> Non-Conformance	Yes, also described during the verification and review process directly with reviewer.	11/17/2020
1.32	Did the reviewer find that the methods used were scientifically and technically valid?	<input checked="" type="checkbox"/> Requirement <input type="checkbox"/> Not Applicable	<input checked="" type="checkbox"/> Conformance <input type="checkbox"/> Non-Conformance	Yes, technical validity was achieved.	11/17/2020
1.33	If the LCA was comparative in nature, were the product systems of the compared products deemed to be equivalent?	<input type="checkbox"/> Requirement <input checked="" type="checkbox"/> Not Applicable	<input type="checkbox"/> Conformance <input type="checkbox"/> Non-Conformance		
1.34	If the LCA was comparative in nature, were the functional units of the compared products deemed to be equivalent?	<input type="checkbox"/> Requirement <input checked="" type="checkbox"/> Not Applicable	<input type="checkbox"/> Conformance <input type="checkbox"/> Non-Conformance		
1.35	If the LCA was comparative in nature were the data collection and use choices reasonable to allow for a fair and equivalent comparison?	<input type="checkbox"/> Requirement <input checked="" type="checkbox"/> Not Applicable	<input type="checkbox"/> Conformance <input type="checkbox"/> Non-Conformance		

1.36	If the LCA was comparative in nature, were the environmental impact category choices reasonable to allow for a fair and equivalent comparison?	<input type="checkbox"/> Requirement <input checked="" type="checkbox"/> Not Applicable	<input type="checkbox"/> Conformance <input type="checkbox"/> Non-Conformance		
2 Review of General Elements of Report					
2.1	Are the collection methods used for primary data described and reasonable?	<input checked="" type="checkbox"/> Requirement <input type="checkbox"/> Not Applicable	<input checked="" type="checkbox"/> Conformance <input type="checkbox"/> Non-Conformance	Yes, throughout the report, supplemental information and discussion with practitioner.	11/17/2020
2.2	Are sources/published literature adequately referenced?	<input checked="" type="checkbox"/> Requirement <input type="checkbox"/> Not Applicable	<input checked="" type="checkbox"/> Conformance <input type="checkbox"/> Non-Conformance	Yes	11/17/2020
2.3	Is the reference unit of data stated for each input?	<input checked="" type="checkbox"/> Requirement <input type="checkbox"/> Not Applicable	<input checked="" type="checkbox"/> Conformance <input type="checkbox"/> Non-Conformance	Yes	11/17/2020
2.4	Is the geographical representativeness of data for each input clear?	<input checked="" type="checkbox"/> Requirement <input type="checkbox"/> Not Applicable	<input checked="" type="checkbox"/> Conformance <input type="checkbox"/> Non-Conformance	Yes, Section 3.10.3.	11/17/2020
2.5	Is the technological representativeness of the data for each input clear?	<input checked="" type="checkbox"/> Requirement <input type="checkbox"/> Not Applicable	<input checked="" type="checkbox"/> Conformance <input type="checkbox"/> Non-Conformance	Yes, Section 3.10.3.	11/17/2020
2.6	Is data relevant and appropriate for the allocation among co-products?	<input checked="" type="checkbox"/> Requirement <input type="checkbox"/> Not Applicable	<input checked="" type="checkbox"/> Conformance <input type="checkbox"/> Non-Conformance	No co-products.	11/17/2020
2.7	Is the period of data collection clear and appropriate?	<input checked="" type="checkbox"/> Requirement <input type="checkbox"/> Not Applicable	<input checked="" type="checkbox"/> Conformance <input type="checkbox"/> Non-Conformance	Yes – Table 2	11/17/2020
2.8	What time period does the data represent and is it consistent for all inputs? If it is inconsistent across all inputs, is the reason for the inconsistency stated and reasonable?	<input checked="" type="checkbox"/> Requirement <input type="checkbox"/> Not Applicable	<input checked="" type="checkbox"/> Conformance <input type="checkbox"/> Non-Conformance	Yes - 2019	11/17/2020
2.9	Were any data excluded? If yes, what is the justification of the excluded data. Is the justification adequate and warranted?	<input checked="" type="checkbox"/> Requirement <input type="checkbox"/> Not Applicable	<input checked="" type="checkbox"/> Conformance <input type="checkbox"/> Non-Conformance	Yes, however within cut-off criteria of below 5% by mass.	11/17/2020
2.10	Is the source of each data input clear?	<input checked="" type="checkbox"/> Requirement <input type="checkbox"/> Not Applicable	<input checked="" type="checkbox"/> Conformance <input type="checkbox"/> Non-Conformance	Yes, Table 5	11/17/2020
2.11	Did the practitioner state data quality requirements? Does all data meet initial stated quality requirements?	<input checked="" type="checkbox"/> Requirement <input type="checkbox"/> Not Applicable	<input checked="" type="checkbox"/> Conformance <input type="checkbox"/> Non-Conformance	Yes Section 3.10 and discussed.	11/17/2020

2.12	Was the choice of data unbiased so that it did not favor those participating in or financing study?	<input checked="" type="checkbox"/> Requirement <input type="checkbox"/> Not Applicable	<input checked="" type="checkbox"/> Conformance <input type="checkbox"/> Non-Conformance	Yes, reviewer found that that the choice of data did not bias the study.	11/17/2020
2.13	Were quality assurance and validation procedures used? Does the reviewer consider them to be adequate to meet the goal of the study?	<input checked="" type="checkbox"/> Requirement <input type="checkbox"/> Not Applicable	<input checked="" type="checkbox"/> Conformance <input type="checkbox"/> Non-Conformance	Discussed and found to be appropriate.	11/17/2020
2.14	Were the results of validation methods reviewed by someone other than the LCA practitioner?	<input checked="" type="checkbox"/> Requirement <input type="checkbox"/> Not Applicable	<input checked="" type="checkbox"/> Conformance <input type="checkbox"/> Non-Conformance	Reviewed by reviewers in critical review process.	11/17/2020
2.15	Overall, is data reasonable and appropriate in relation to the goal of the study?	<input checked="" type="checkbox"/> Requirement <input type="checkbox"/> Not Applicable	<input checked="" type="checkbox"/> Conformance <input type="checkbox"/> Non-Conformance	Yes	11/17/2020
2.16	If allocation was used, was the basis of allocation clear (i.e physical or economical)?	<input checked="" type="checkbox"/> Requirement <input type="checkbox"/> Not Applicable	<input checked="" type="checkbox"/> Conformance <input type="checkbox"/> Non-Conformance	Yes – mass based and checked in sensitivity analysis while comparing with economic allocation.	11/17/2020
2.17	If allocation was used, were the allocation methods described, documented and justified for each unit process in which allocation was made?	<input checked="" type="checkbox"/> Requirement <input type="checkbox"/> Not Applicable	<input checked="" type="checkbox"/> Conformance <input type="checkbox"/> Non-Conformance	Yes	11/17/2020
2.18	If allocation was used, were the allocation methods applied in a way that did not bias the study so that it did not favor those participating in or financing study?	<input checked="" type="checkbox"/> Requirement <input type="checkbox"/> Not Applicable	<input checked="" type="checkbox"/> Conformance <input type="checkbox"/> Non-Conformance	Yes	11/17/2020
2.20	Was a sensitivity analysis conducted to compare alternative allocation methods?	<input checked="" type="checkbox"/> Requirement <input type="checkbox"/> Not Applicable	<input checked="" type="checkbox"/> Conformance <input type="checkbox"/> Non-Conformance	Section 5.6. Yes - mass based and checked in sensitivity analysis with economic allocation.	11/17/2020
2.20	If allocation was used, were the allocation methods used consistently across the entire product system? Did the LCA Reviewer find the inconsistencies to be warranted?	<input checked="" type="checkbox"/> Requirement <input type="checkbox"/> Not Applicable	<input checked="" type="checkbox"/> Conformance <input type="checkbox"/> Non-Conformance	Yes – found to be consistent.	11/17/2020
3	Review of Impact Assessment				
3.1	Is there a statement that explains the relative expression of results?	<input checked="" type="checkbox"/> Requirement <input type="checkbox"/> Not Applicable	<input checked="" type="checkbox"/> Conformance <input type="checkbox"/> Non-Conformance	Yes – Section 5.1.	11/17/2020
3.2	Are the chosen impact categories justified and valid?	<input checked="" type="checkbox"/> Requirement <input type="checkbox"/> Not Applicable	<input checked="" type="checkbox"/> Conformance <input type="checkbox"/> Non-Conformance	Yes – Section 5.1.	11/17/2020

3.3	Was the impact assessment carried out in a way that is scientifically and technically valid?	<input checked="" type="checkbox"/> Requirement <input type="checkbox"/> Not Applicable	<input checked="" type="checkbox"/> Conformance <input type="checkbox"/> Non-Conformance	Yes – TRACI and ReCiPe	11/17/2020
3.4	Were methods, such as weighting, used to group or analyze results? If used were the methods described adequately? Additionally, were the methods applied in a way that did not bias the results of the study?	<input checked="" type="checkbox"/> Requirement <input type="checkbox"/> Not Applicable	<input checked="" type="checkbox"/> Conformance <input type="checkbox"/> Non-Conformance	Yes – weighting not used.	11/17/2020
3.5	Does the interpretation include a data quality assessment or a discussion of the data quality assessment?	<input checked="" type="checkbox"/> Requirement <input type="checkbox"/> Not Applicable	<input checked="" type="checkbox"/> Conformance <input type="checkbox"/> Non-Conformance	Yes – Section 6	11/17/2020
3.6	Does the interpretation include a sensitivity analysis or a discussion of a sensitivity analysis that was conducted, if necessary?	<input checked="" type="checkbox"/> Requirement <input type="checkbox"/> Not Applicable	<input checked="" type="checkbox"/> Conformance <input type="checkbox"/> Non-Conformance	Yes – Section 5.6	11/17/2020
3.7	Did the LCA reviewer find that significant findings were discussed adequately.	<input checked="" type="checkbox"/> Requirement <input type="checkbox"/> Not Applicable	<input checked="" type="checkbox"/> Conformance <input type="checkbox"/> Non-Conformance	Yes – Section 5 and 6	11/17/2020
3.8	Did the LCA reviewer find that the role of excluded elements was evaluated and discussed adequately.	<input checked="" type="checkbox"/> Requirement <input type="checkbox"/> Not Applicable	<input checked="" type="checkbox"/> Conformance <input type="checkbox"/> Non-Conformance	Yes – Section 3.10.4	11/17/2020
3.9	Did the LCA reviewer find that the study included an adequate discussion of the consistency and reproducibility of the methods applied in the LCA?	<input checked="" type="checkbox"/> Requirement <input type="checkbox"/> Not Applicable	<input checked="" type="checkbox"/> Conformance <input type="checkbox"/> Non-Conformance	Yes – Section 3 and 4.	11/17/2020
3.10	Did the LCA reviewer find that the study included an adequate discussion of the precision, completeness and representativeness of data used in the study?	<input checked="" type="checkbox"/> Requirement <input type="checkbox"/> Not Applicable	<input checked="" type="checkbox"/> Conformance <input type="checkbox"/> Non-Conformance	Yes – Section 3.10.3	11/17/2020
3.11	Did the LCA reviewer find that the study included an adequate discussion related to the impact of value judgments on the results	<input checked="" type="checkbox"/> Requirement <input type="checkbox"/> Not Applicable	<input checked="" type="checkbox"/> Conformance <input type="checkbox"/> Non-Conformance	Yes – Section 5.6, sensitivity analysis has been conducted.	11/17/2020

COMPLIANCE TO LIVING PRODUCT CHALLENGE 2.0 LCA-BASED REQUIREMENTS

Element	Applicability	Conformance Status	Review Comments <small>(Reviewer Comments in Black, LCA Practitioner Comments in Red)</small>	Approval Date	
1	G-04 Life Cycle Assessment General Requirements				
1.1	All manufacturers must produce and maintain an LCA Model demonstrating the product's cradle-to-grave impacts.	<input checked="" type="checkbox"/> Requirement <input type="checkbox"/> Recommendation	<input checked="" type="checkbox"/> Conformance <input type="checkbox"/> Non-Conformance	Model collected and reviewed.	11/17/2020
1.2	Performed in accordance with a relevant product category rule (PCR) to ISO 14040/44.	<input checked="" type="checkbox"/> Requirement <input type="checkbox"/> Recommendation	<input checked="" type="checkbox"/> Conformance <input type="checkbox"/> Non-Conformance	LCA complies with BIFMA PCR for Seating.	11/17/2020
1.3	Critically reviewed by a third party for conformance with ISO 14044.	<input checked="" type="checkbox"/> Requirement <input type="checkbox"/> Recommendation	<input checked="" type="checkbox"/> Conformance <input type="checkbox"/> Non-Conformance	Review conducted and passed.	11/17/2020
1.4	Has either been performed by an LCA Certified Practitioner certified by ACLCA (https://aclca.org/lcaccp-certification/) or by an ILFI-approved LCA practitioner or consultancy?	<input checked="" type="checkbox"/> Requirement <input type="checkbox"/> Recommendation	<input checked="" type="checkbox"/> Conformance <input type="checkbox"/> Non-Conformance	Yes, ACLCA Certified Practitioner	11/17/2020
1.5	Has either been performed by an LCA Certified Practitioner certified by ACLCA (https://aclca.org/lcaccp-certification/) or by an ILFI-approved LCA practitioner or consultancy?	<input checked="" type="checkbox"/> Requirement <input type="checkbox"/> Recommendation	<input checked="" type="checkbox"/> Conformance <input type="checkbox"/> Non-Conformance	Hotspots identified. 5.3,5.4,5.5	11/17/2020
1.6	The LCA should clearly demonstrate the product's contributions to, at minimum, fossil-based energy, water, and greenhouse gas (GHG) emissions	<input checked="" type="checkbox"/> Requirement <input type="checkbox"/> Recommendation	<input checked="" type="checkbox"/> Conformance <input type="checkbox"/> Non-Conformance	LCA valid for 3 years.	11/17/2020
1.7	LCA models must be valid at the time of certification and for the duration of the 3-Year certification period. If the LCA will expire before recertification, an updated LCA must be resubmitted at the next annual check-in following its expiration.	<input checked="" type="checkbox"/> Requirement <input type="checkbox"/> Recommendation	<input checked="" type="checkbox"/> Conformance <input type="checkbox"/> Non-Conformance	Any updates in the LCA will be communicated to the reviewer and verified before applying for recertification.	11/17/2020
2	I04-5 Water Hotspot Identification				

2.1	A table of process contributions to cradle-to-gate life cycle water consumption, listing at least the top 5 processes ranked in terms of water consumption.	<input checked="" type="checkbox"/> Requirement <input type="checkbox"/> Recommendation	<input checked="" type="checkbox"/> Conformance <input type="checkbox"/> Non-Conformance	Section 5.5	11/17/2020
2.2	A brief 1-2 paragraph narrative that interprets the main results and identifies the 5 main drivers of the product's water consumption footprints.	<input type="checkbox"/> Requirement <input checked="" type="checkbox"/> Recommendation	<input checked="" type="checkbox"/> Conformance <input type="checkbox"/> Non-Conformance	Section 5.5	11/17/2020
3	I06-6 Energy Hotspot Identification				
3.1	A table of process contributions to cradle-to-gate life cycle water consumption, listing at least the top 5 processes ranked in terms of energy consumption.	<input checked="" type="checkbox"/> Requirement <input type="checkbox"/> Recommendation	<input checked="" type="checkbox"/> Conformance <input type="checkbox"/> Non-Conformance	Section 5.3	11/17/2020
3.2	A brief one- to two-page narrative that interprets the results and identifies the five main drivers of the product's cradle-to-gate fossil energy consumption footprints.	<input type="checkbox"/> Requirement <input checked="" type="checkbox"/> Recommendation	<input checked="" type="checkbox"/> Conformance <input type="checkbox"/> Non-Conformance	Section 5.3	11/17/2020
4	I14-4 Carbon Hotspot Identification				
4.1	A table of process contributions to cradle-to-gate life cycle water consumption, listing at least the top 5 processes ranked in terms of GHG emissions.	<input checked="" type="checkbox"/> Requirement <input type="checkbox"/> Recommendation	<input checked="" type="checkbox"/> Conformance <input type="checkbox"/> Non-Conformance	Section 5.4	11/17/2020
4.2	A brief narrative that interprets the results and identifies the 5 main drivers of the product's cradle-to-gate carbon Footprints, and their relevance.	<input type="checkbox"/> Requirement <input checked="" type="checkbox"/> Recommendation	<input checked="" type="checkbox"/> Conformance <input type="checkbox"/> Non-Conformance	Section 5.4	11/17/2020

COMPLIANCE TO LEED V4.1 LCA-BASED REQUIREMENTS

	Element	Applicability	Conformance Status	Review Comments <small>(Reviewer Comments in Black. LCA Practitioner Comments in Red)</small>	Approval Date
1	BPDO - Environmental Product Declaration – Public Life Cycle Assessment Option (1 pt.)				
1.1	Publicly Available	<input checked="" type="checkbox"/> Requirement <input type="checkbox"/> Recommendation	<input checked="" type="checkbox"/> Conformance <input type="checkbox"/> Non-Conformance	https://www.humanscale.com/resources/designer-toolkit/green-design.cfm	11/17/2020
1.2	Critically Reviewed	<input checked="" type="checkbox"/> Requirement <input type="checkbox"/> Recommendation	<input checked="" type="checkbox"/> Conformance <input type="checkbox"/> Non-Conformance	Yes.	11/17/2020
1.3	ISO14044 Compliant	<input checked="" type="checkbox"/> Requirement <input type="checkbox"/> Recommendation	<input checked="" type="checkbox"/> Conformance <input type="checkbox"/> Non-Conformance	Critical review confirmed conformance.	11/17/2020
1.4	At Least Cradle to Gate in Scope	<input checked="" type="checkbox"/> Requirement <input type="checkbox"/> Recommendation	<input checked="" type="checkbox"/> Conformance <input type="checkbox"/> Non-Conformance	Yes, cradle to grave in scope.	11/17/2020
1.5	Cover or Summary Sheet that includes: -All requirements outlined in LEED v4 reference guide for this section -The type of LCA software used to conduct the assessment; -Date of assessment with period of validity or expiration date of life cycle assessment, -URL link to the publicly available version of the document.	<input checked="" type="checkbox"/> Requirement <input type="checkbox"/> Recommendation	<input checked="" type="checkbox"/> Conformance <input type="checkbox"/> Non-Conformance	Yes, pages 2 and 3 of the document.	11/17/2020

BIFMA PCR FOR SEATING: UNCPC 3811 VERSION 3

	Element	Applicability	Conformance Status	Review Comments <small>(Reviewer Comments in Black. LCA Practitioner Comments in Red)</small>	Approval Date
1	Goal and Scope Requirements for the LCA study				
1.1	Is the scope cradle-to-grave?	<input checked="" type="checkbox"/> Requirement <input type="checkbox"/> Recommendation	<input checked="" type="checkbox"/> Conformance <input type="checkbox"/> Non-Conformance	Section 3.3	11/17/2020
1.2	Does product description include name of manufacturer, model number, general description, and a picture?	<input checked="" type="checkbox"/> Requirement <input type="checkbox"/> Recommendation	<input checked="" type="checkbox"/> Conformance <input type="checkbox"/> Non-Conformance	Section 3.2.1	11/17/2020
1.3	Functional unit equals one unit of seating to seat one individual, for a period of 10 years? (note: results shall not be normalized from a fraction of a chair)	<input checked="" type="checkbox"/> Requirement <input type="checkbox"/> Recommendation	<input checked="" type="checkbox"/> Conformance <input type="checkbox"/> Non-Conformance	Section 3.1	11/17/2020
1.4	Do products designed for 10 or more years use only 1 unit for ref flow (1 unit for 10 years max)?	<input checked="" type="checkbox"/> Requirement <input type="checkbox"/> Recommendation	<input checked="" type="checkbox"/> Conformance <input type="checkbox"/> Non-Conformance	Section 3.1. Yes.	11/17/2020
1.5	Do products that have warranty periods and/or designed for less than 10 yrs report the necessary number of units for the 10 yr period?	<input checked="" type="checkbox"/> Requirement <input type="checkbox"/> Recommendation	<input checked="" type="checkbox"/> Conformance <input type="checkbox"/> Non-Conformance	Section 3.1. No	11/17/2020
1.6	If product meets ANSI/BIFMA X5.1, is the service life given as 10 yrs?	<input checked="" type="checkbox"/> Requirement <input type="checkbox"/> Recommendation	<input checked="" type="checkbox"/> Conformance <input type="checkbox"/> Non-Conformance	Table 1. Yes.	11/17/2020
1.7	If product does not meet ANSI/BIFMA X5.1, and the warranty period is: - 5 years or more, is the product service life given as 5 years - less than 5 years, is service life equal to warranty period?	<input checked="" type="checkbox"/> Requirement <input type="checkbox"/> Recommendation	<input checked="" type="checkbox"/> Conformance <input type="checkbox"/> Non-Conformance	Not applicable since product meets ANSI/BIFMA X5.1.	11/17/2020

1.6	Are all known flows that are knowingly omitted, justified? All known energy flows greater than 1% shall be included. Cumulative mass and energy omissions shall not exceed 5%	<input checked="" type="checkbox"/> Requirement <input type="checkbox"/> Recommendation	<input checked="" type="checkbox"/> Conformance <input type="checkbox"/> Non-Conformance	Section 3.8 and confirmed in background data and LCA practitioner interviews.	11/17/2020
2	System Boundaries				
2.1	Does the LCA report detail the system boundaries, including a description of LC stages for the product?	<input checked="" type="checkbox"/> Requirement <input type="checkbox"/> Recommendation	<input checked="" type="checkbox"/> Conformance <input type="checkbox"/> Non-Conformance	Figure 2 and throughout the document.	11/17/2020
2.3	Is transportation of materials included in LC impact assessment? This includes transport between stages and within the manufacturing stage between facilities owned by the company.	<input checked="" type="checkbox"/> Requirement <input type="checkbox"/> Recommendation	<input checked="" type="checkbox"/> Conformance <input type="checkbox"/> Non-Conformance	Table 2 and LCA practitioner interviews	11/17/2020
3	Upstream Stage				
3.1	Are primary data used for upstream processes, if available? If not, secondary data may be used.	<input checked="" type="checkbox"/> Requirement <input type="checkbox"/> Recommendation	<input checked="" type="checkbox"/> Conformance <input type="checkbox"/> Non-Conformance	Ecoinvent secondary data primarily used for upstream.	11/17/2020
3.2	If using a dataset for upstream without transport embedded, are trans distances consistent with those given in Table 1 of PCR? (NA -based)	<input checked="" type="checkbox"/> Requirement <input type="checkbox"/> Recommendation	<input checked="" type="checkbox"/> Conformance <input type="checkbox"/> Non-Conformance	For the most part, transportation distances embedded.	11/17/2020
4	Production Stage/EOL stages				
4.1	Are primary data used, where available, for production processes under control of mfr? -- Not sure this is required.	<input checked="" type="checkbox"/> Requirement <input type="checkbox"/> Recommendation	<input checked="" type="checkbox"/> Conformance <input type="checkbox"/> Non-Conformance	From primary data review and LCA practitioner interview. For the most part primary data was used where available.	11/17/2020
4.2	Absent primary data, is the trans distance used for process waste recycling/recovery/disposal processes 20 miles (32 km) within NA?	<input checked="" type="checkbox"/> Requirement <input type="checkbox"/> Recommendation	<input checked="" type="checkbox"/> Conformance <input type="checkbox"/> Non-Conformance	Section 3.5 and confirmed in primary data provided during review.	11/17/2020
4.3	If primary data are not used for EOL, is the distribution of materials at EOL aligned with an approved guidance (see PCR)? Are Non recycled materials must be modeled as 80% landfilled/20% incineration?	<input checked="" type="checkbox"/> Requirement <input type="checkbox"/> Recommendation	<input checked="" type="checkbox"/> Conformance <input type="checkbox"/> Non-Conformance	Section 3.7 and confirmed in LCA model review.	11/17/2020
5	Allocation and Units				

5.1	When allocation cannot be avoided, does allocation follow either mass (or other biophysical relationship) or economic allocation methods? If not, are deviations justified?	<input checked="" type="checkbox"/> Requirement <input type="checkbox"/> Recommendation	<input checked="" type="checkbox"/> Conformance <input type="checkbox"/> Non-Conformance	Section 3.9	11/17/2020
5.2	For allocation due to recycling, the recycled content method shall be used. If not, are deviations justified?	<input checked="" type="checkbox"/> Requirement <input type="checkbox"/> Recommendation	<input checked="" type="checkbox"/> Conformance <input type="checkbox"/> Non-Conformance	Section 3.9 and confirmed by model review.	11/17/2020
5.3	Are units given in SI units with no more than 3 significant digits?	<input checked="" type="checkbox"/> Requirement <input type="checkbox"/> Recommendation	<input checked="" type="checkbox"/> Conformance <input type="checkbox"/> Non-Conformance	Yes. Throughout the document.	11/17/2020
6	Calculation Rules and Data Requirements				
6.1	For facilities under the control of the manufacturer, are primary data used? If multiple locations mfr the components, a single source can be used as representative data, or an average, may be used for operations contributing less than 10% of the total prod output.	<input checked="" type="checkbox"/> Requirement <input type="checkbox"/> Recommendation	<input checked="" type="checkbox"/> Conformance <input type="checkbox"/> Non-Conformance	Review of primary data and LCA model.	11/17/2020
6.2	For the US, are energy data aligned with region of mfr? Out of the US, is a reasonable and justified source used?	<input checked="" type="checkbox"/> Requirement <input type="checkbox"/> Recommendation	<input checked="" type="checkbox"/> Conformance <input type="checkbox"/> Non-Conformance	Review of primary data and LCA model. Sources mentioned in Table 5.	11/17/2020
6.3	Are primary data used for unit processes that contribute to the majority of mass and energy flows, or which have the most relevant env emissions?	<input checked="" type="checkbox"/> Requirement <input type="checkbox"/> Recommendation	<input checked="" type="checkbox"/> Conformance <input type="checkbox"/> Non-Conformance	Yes, primary data has been used when available. Otherwise, third-party verified secondary datasets (ecoinvent) has been used.	11/17/2020
6.4	Is a data quality assessment conforming to ISO 14044 presented?	<input checked="" type="checkbox"/> Requirement <input type="checkbox"/> Recommendation	<input checked="" type="checkbox"/> Conformance <input type="checkbox"/> Non-Conformance	See 14044 checklist.	11/17/2020
6.5	Are data obtained from the manufacturer considered average monthly data for the year of study?	<input checked="" type="checkbox"/> Requirement <input type="checkbox"/> Recommendation	<input checked="" type="checkbox"/> Conformance <input type="checkbox"/> Non-Conformance	Yes. Review of primary data and LCA model.	11/17/2020
6.6	Is documentation given for all individual data sources?	<input checked="" type="checkbox"/> Requirement <input type="checkbox"/> Recommendation	<input checked="" type="checkbox"/> Conformance <input type="checkbox"/> Non-Conformance	Table 5	11/17/2020
6.7	Are primary energy data or appropriate regional secondary energy sources used? If not, does the source of energy data comply with guidance given in the PCR?	<input checked="" type="checkbox"/> Requirement <input type="checkbox"/> Recommendation	<input checked="" type="checkbox"/> Conformance <input type="checkbox"/> Non-Conformance	Yes, see Table 5. Review of primary data and LCA model.	11/17/2020

6.8	Are carbon offsets excluded from the inventory?	<input checked="" type="checkbox"/> Requirement <input type="checkbox"/> Recommendation	<input checked="" type="checkbox"/> Conformance <input type="checkbox"/> Non-Conformance	Yes, no carbon offsets utilized.	11/17/2020
6.9	Do the LCA Impacts include each of the following in TRACI 2.1: Global Warming Potential Acidification Ozone Creations (POCP) Eutrophication Ozone Depletion	<input checked="" type="checkbox"/> Requirement <input type="checkbox"/> Recommendation	<input checked="" type="checkbox"/> Conformance <input type="checkbox"/> Non-Conformance	Section 5.1	11/17/2020
6.10	Are life cycle impacts reported per life cycle stage and in total?	<input checked="" type="checkbox"/> Requirement <input type="checkbox"/> Recommendation	<input checked="" type="checkbox"/> Conformance <input type="checkbox"/> Non-Conformance	See Section 5.	11/17/2020
6.11	Has a sensitivity analysis been performed confirming that an appropriate model was used?	<input checked="" type="checkbox"/> Requirement <input type="checkbox"/> Recommendation	<input checked="" type="checkbox"/> Conformance <input type="checkbox"/> Non-Conformance	See section 5.6	11/17/2020

LCA MODEL REVIEW CHECKLIST

	Plan Hierarchy	Process Name	Appropriate Inputs/outputs	Connection Check	Mass Balance Check	Datasets Appropriate	Notes
Name of final plan: ecoinvent_36_humanscale_cinto.zolca							
1	Cinto	Cinto Cradle to Gate (Dub)	Confirmed	Confirmed	Confirmed	Confirmed	
2		Cinto Cradle to Gate (Pisc)	Confirmed	Confirmed	Confirmed	Confirmed	
3		Cinto Cradle to Gate (Fres)	Confirmed	Confirmed	Confirmed	Confirmed	
4		Cinto Cradle to Grave (Dub)	Confirmed	Confirmed	Confirmed	Confirmed	
5		Cinto Cradle to Grave (Pisc)	Confirmed	Confirmed	Confirmed	Confirmed	
6		Cinto Cradle to Grave (Fres)	Confirmed	Confirmed	Confirmed	Confirmed	
7		Cinto EOL Disposal	Confirmed	Confirmed	Confirmed	Confirmed	
8		Cinto EOL Transport	Confirmed	Confirmed	Confirmed	Confirmed	
9		Cinto MatExtract (Pisc)	Confirmed	Confirmed	Confirmed	Confirmed	
10		Cinto MatTrans (Pisc)	Confirmed	Confirmed	Confirmed	Confirmed	
11		Cinto Trspt to HS (Pisc)	Confirmed	Confirmed	Confirmed	Confirmed	
12		Cinto Trspt to HS (Dub)	Confirmed	Confirmed	Confirmed	Confirmed	
13		Cinto Trspt to HS (Fres)	Confirmed	Confirmed	Confirmed	Confirmed	
14		Cinto Trspt to Cust (Dub)	Confirmed	Confirmed	Confirmed	Confirmed	
15		Cinto Trspt to Cust (Fres)	Confirmed	Confirmed	Confirmed	Confirmed	
16		Cinto Trspt to Cust (Pisc)	Confirmed	Confirmed	Confirmed	Confirmed	
17	All Cinto Chairs	Assembly (Dub)	Confirmed	Confirmed	Confirmed	Confirmed	
18	All Cinto Chairs	Assembly (Pisc)	Confirmed	Confirmed	Confirmed	Confirmed	
19	All Cinto Chairs	Assembly (Fres)	Confirmed	Confirmed	Confirmed	Confirmed	

20	All Cinto Chairs	Chair Maintenance	Confirmed	Confirmed	Confirmed	Confirmed	
----	---------------------	-------------------	-----------	-----------	-----------	-----------	--